

The drum elevators are made of welded steel (zincd for Mod. CVI 602), with a protective coating; the frame is completely detachable to reduce dimensions during transport. Each drum elevator is provided with a support with fixed wedges for wooden drums of conductors and with one mechanical disk braking system to control the drum when unwinding the conductor

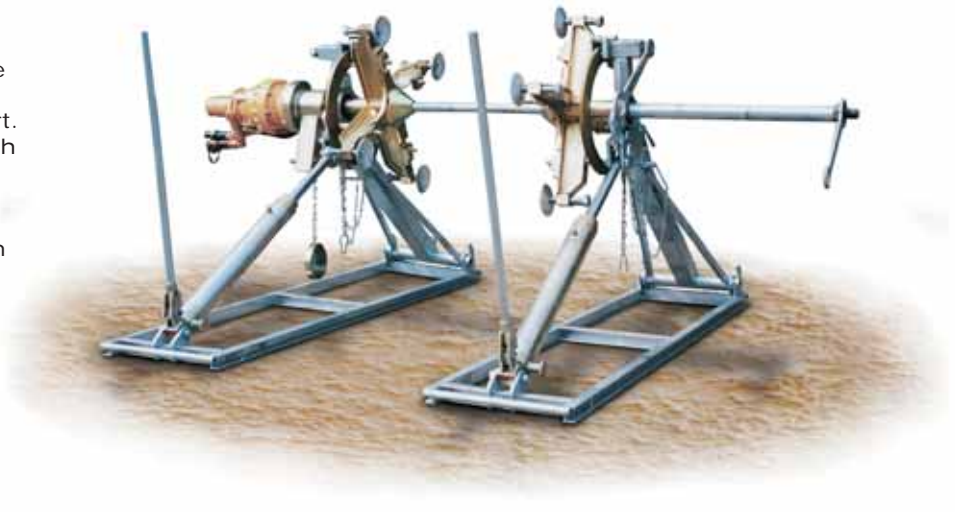

Certified Quality System
ISO 9001:2000

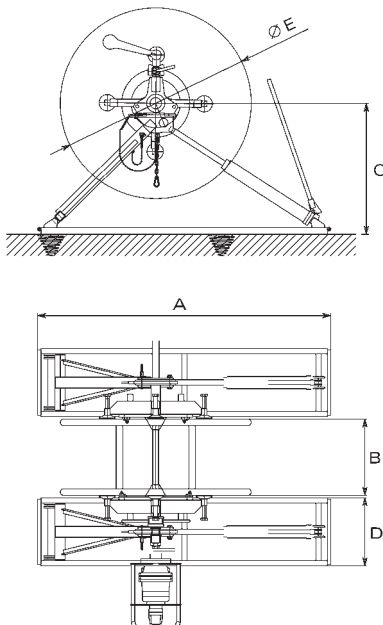

Model	Dimensions [mm]								Capacity [kN]	Mass [kg]
	A	Bmin	Bmax	Cmin	Cmax	D	Emin	Emax		
CVI 400	1650	600	1500	500	1100	550	1100	2000	60	284
CVI 602	2150	500	1500	500	1400	500	750	2500	70	330



Included in the Mod. CVI 602



Mod. TIH 002

OPTIONAL FOR CVI 602

- CDA 009** Adapter for steel rope standard reels
- TIH 002** Fast assembling hydraulic motor for control of the drum winding and unwinding
- CDF 051** Second disc brake

Max Torque [kNxm]	Max rotating speed [RPM]	Mass [kg]
1.8	45	78

Kit of connecting hoses

- TUT 001** length 7 m, mass 11 kg
- TUT 002** length 10 m, mass 15 kg
- TUT 003** length 15 m, mass 23 kg